



# Mini Moving Head User Manual

---

**SEVEN STARS**®

# Mini Moving Head User Manual

## Model: LM70

### Attention

- 1、 Please read these operating instructions carefully to familiarize you with basic operations of this unit BEFORE USE.
- 2、 Without permitted, it is prohibited to spread the contents of this manual to others.
- 3、 This manual is only to provide related information, and the contents of this manual will be changed at any time without notice. Unless the instructions have already stated, please do not freely modified the unit.

**All products made from Big Dipper Laser Company have anti - fake identification. please verify the anti-counterfeit label at the bottom of the case to ensure the interests of consumers.**

12	0-255	Color Speed
13		Auto
	0-7	MOVEMENT(AUTO & SOUND EFFECT)
	8-22	Auto 1
	23-37	Auto 2
	38-53	Auto 3
	54-67	Auto 4
	68-82	Auto 5
	83-97	Auto 6
	98-112	Auto 7
	113-127	Auto 8
	128-142	Sound 1
	143-157	Sound 2
	158-172	Sound 3
	173-187	Sound 4
	188-202	Sound 5
203-217	Sound 6	
218-232	Sound 7	
233-255	Sound 8	
14	150-255	Reset

## Technical parameters

Model Parameters	LM70
Light Source	7*8W 4-in-1 Led (RGBW)
Power Supply	100-240V/50-60HZ
Rated Power	100W
Control Mode	Auto/Sound/DMX/Master-slave
DMX Channel	9/14
Product Size	175*175*235mm
N.W./G.W.	2.7/3.5kg
In the box	Power cable x1; Handle x1; Screw x2; User Manual x1

## Control Panel Instruction:

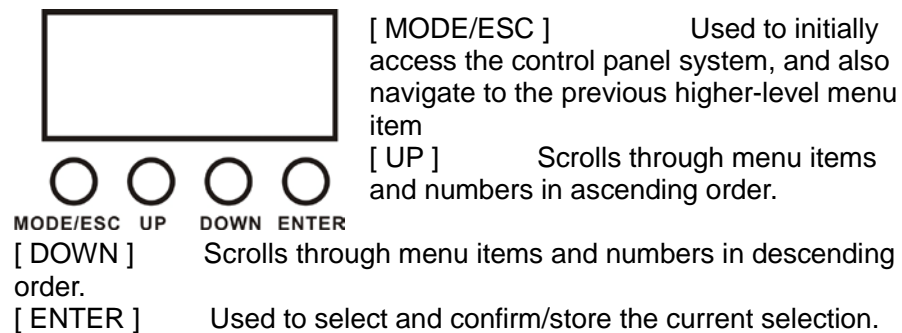

## Operation Instruction

### Controller Settings

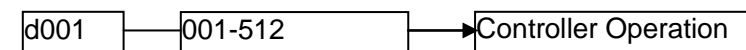

### Mode Setting

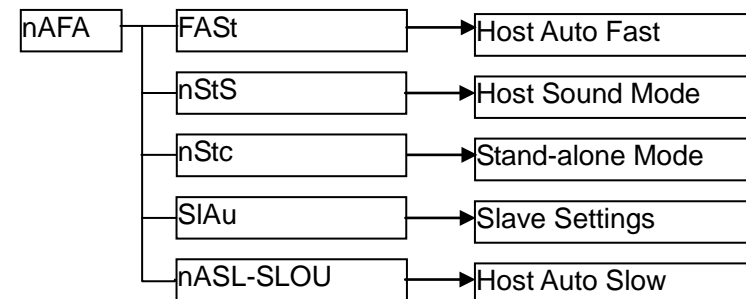

### Motor Rotating Setting

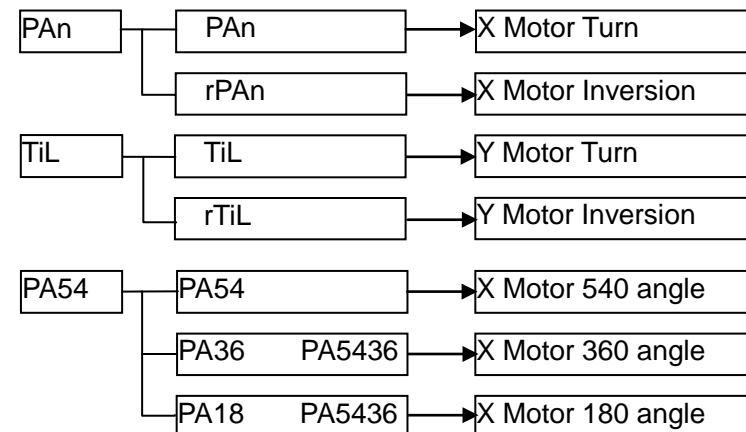

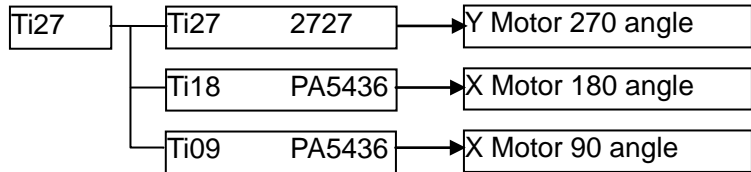

### LED Display Direction Setting

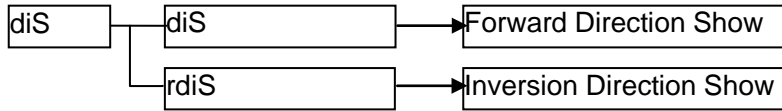

### Channel Mode Setting

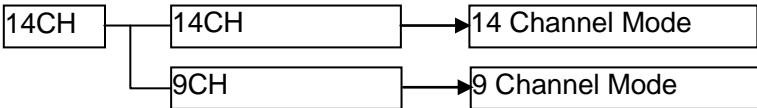

### Reset Setting

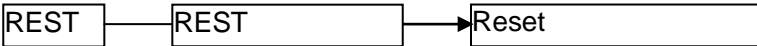

### Initialization Setting



Remark: When the operation mode is chosen, press the Enter button to run.

## 9 Channels Mode

Channel			Function
1	X Axis	0-255	
2	Y Axis	0-255	
3	Master Control	0-8	Light off
		8-135	Dimming
		136-240	Strobe
		241-255	Power ON/OFF
4	R LED Dimming	0-255	Dimming from dark to bright
5	G LED Dimming	0-255	Dimming from dark to bright
6	B LED Dimming	0-255	Dimming from dark to bright
7	W LED Dimming	0-255	Dimming from dark to bright
8	Speed	0-255	XY Motor Speed
9	Reset	150-200	

## 14 Channels Mode

Channel		Function
1	0-255	Pan
2	0-255	Pan fine
3	0-255	Tilt
4	0-255	Tilt fine
5	0-255	Speed
6	0-7	No Effect
	8-134	Dimming
	135-239	Strobe from slow to fast
	240-255	Light on
7	0-255	RED Dimming
8	0-255	Green Dimming
9	0-255	Blue Dimming
10	0-255	White Dimming
11		Color Choose
	0-7	Color Assortment1
	8-21	Color Assortment2
	22-34	Color Assortment3
	35-49	Color Assortment4
	50-63	Color Assortment5
	64-77	Color Assortment6
	78-91	Color Assortment7
	92-105	Color Assortment8
	106-119	Color Assortment9
	120-134	Color Assortment10
	135-147	Color Assortment11
	148-161	Color Assortment12
	162-175	Color Assortment13
	176-189	Color Assortment14
	190-203	Color Assortment15
	204-217	Color Assortment16
218-231	Color Assortment17	
232-255	Color Saltus	